



**HAL**  
open science

## Diversity, Globalisation and Market Stability

Laurence Lasselle, Serge Svizzero, Clement Allan Tisdell

► **To cite this version:**

Laurence Lasselle, Serge Svizzero, Clement Allan Tisdell. Diversity, Globalisation and Market Stability. *Economia Internazionale*, 2001, 54 (3), pp.385-399. hal-02166638

**HAL Id: hal-02166638**

**<https://hal.univ-reunion.fr/hal-02166638>**

Submitted on 27 Jun 2019

**HAL** is a multi-disciplinary open access archive for the deposit and dissemination of scientific research documents, whether they are published or not. The documents may come from teaching and research institutions in France or abroad, or from public or private research centers.

L'archive ouverte pluridisciplinaire **HAL**, est destinée au dépôt et à la diffusion de documents scientifiques de niveau recherche, publiés ou non, émanant des établissements d'enseignement et de recherche français ou étrangers, des laboratoires publics ou privés.

## DIVERSITY, GLOBALISATION AND MARKET STABILITY \*

### 1. INTRODUCTION

Since 1970, the world economy has been characterised by rapid globalisation. Capital and labour have flowed across national frontiers in unprecedented quantities. Increasing globalisation has come about due to the easing of policy barriers to trade and also from technical change. This is a consequence of concerted multilateral efforts (via GATT and WTO rounds), and partly as a result of a shift in the philosophy underlying economic policy, which has favoured economic liberalisation.

As an immediate effect of globalisation, the late twentieth century underwent an impressive degree of economic convergence at least within most OECD countries. The word "economic convergence" has at least two different meanings. Firstly, it is the convergence of what could be measured, such as living standards. Secondly, it is the convergence of behaviours. While the former convergence has been already proved, the latter is more difficult to assess. Indeed, for instance, as noted by Aoki (1998), institutional arrangements of work and trade, have remained remarkably diverse even if economic globalisation tends to reduce diversity in many other areas of the economic field.

The link between globalisation and diversity of behaviours seems to be especially important. This link is very controversial. Some economists maintain that diversity across economies, firms, consumers (e.g. Scitovsky 1976) is an important source for advantages in industrial competitiveness and international trade. Tisdell (1999) argues that industrial diversity plays an important role in continuing industrial development and that it is potentially Paretian valuable from a dynamic point of view. Some others consider that behaviours should be

---

\* Serge Svizzero wishes to thank the French Embassy in Australia for financial support.

homogeneous according to global standards as a consequence of global competitive pressure. Both views show that the link between globalisation and diversity is of great importance.

In this paper we study the influence of this link on market stability. From our point of view, when the diversity of behaviours decreases, it promotes types of behaviour which increase market sensitivity and increase market instability.

This paper is organised as follows. Section 2 deals with some theoretical approaches which emphasise that the heterogeneity of behaviours is required to obtain economic stability. In section 3, we consider the simple cobweb model and we demonstrate that via different channels, globalisation reduces behavioural diversity and therefore implies market instability. By using the same framework, we show that instability and globalisation are positively linked because the latter involves changes of firms' motivations.

## 2. BEHAVIOURAL DIVERSITY AND ECONOMIC STABILITY: SOME THEORETICAL APPROACHES

Our purpose is to show that in many theoretical approaches or paradigms, such as the neo-classical and the Keynesian ones, diversity of behaviours leads to a stronger market stability. This diversity may be about consumers' behaviour (see 2.1) as well as entrepreneurs' expectations (see 2.2).

### 2.1 *Heterogeneous consumers, the "law of demand" and market stability*

Usually when we consider the demand curve for a given market, we draw it as a decreasing function. This is the so-called "law of diminishing demand" (see Samuelson (1947)). However the link between the partial market demand curve and individual demand functions is not obvious.

Walras (1874) derived first the former from the latter by making a strong assumption: he considered additive utility functions with decreasing marginal utilities. Pareto (1896) was the first to realise that without such assumptions, the "law of demand" could not be met. In other words, when it is built on individual demands (which result from utility maximisation under budget constraints), the partial demand curve is not necessarily decreasing. This problem has important consequences since it has direct implications for uniqueness and stability of the economy's equilibria.

Hicks (1946) emphasised this issue saying "... economics is not in the end much interested in the behaviour of single individuals. Its concern is with the behaviour of groups. A study of individual demand is only a means to the study of market demand". Then he clearly stated the problem. He distinguished the individual from the group and studied the properties of demand functions of individuals and groups. For any individual the substitution effect goes in the same direction (i.e. in favour of a larger consumption); therefore, for the group, the substitution effect goes clearly in the same direction. However the income effect does not go in the same direction for everybody. Then the group income effect cannot be quite reliable either.

Given this question, Hildenbrand (1983) showed that when individuals are "different", then the average income effect is negative, and hence the partial market demand curve for every commodity is strictly decreasing. In other words, he demonstrated that heterogeneity in the income distribution may make macroeconomic income effects just weak enough in multimarkets consumer demand analysis to leave us with "nice" substitution effects only. More recently, this approach was used by Grandmont (1993) in order to show that demand heterogeneity may generate concave revenue functions and promote imperfect competition.

This strong result is applied to solve partial as well as general equilibrium problems. Implicitly Hildenbrand highlighted two things: on the one hand, concepts which are used in theory in order to globalise such as the "representative consumer" do not simplify necessarily the analysis and might be misleading, and on the other hand, he stressed the importance of diversity. He showed that aggregating individual demands over a large group of individuals (who may differ only in their total expenditure, the latter could be distributed uniformly over the interval  $[0,1]$ ) could lead to properties of the market demand curve which, in general, individual demands do not possess. Diversity in individuals demand functions introduces a qualitative difference in market and individual demand functions.

The importance of diversity from other points of view as far as economic supply is concerned was also stressed in Tisdell (1968, 1986).

## *2.2. Diversity of expectations, effective demand and macro-economic stability*

In the "General Theory", Keynes (1936) showed that entrepreneurs' expectations were central. Indeed at any date, the

current levels of output and employment directly depend, in this approach, on entrepreneurs' expectations about the demand for the goods. This is the so-called "effective demand principle".

At the same time, Keynes demonstrated that active economic policies were necessary because entrepreneurs' plans could lead to low levels of economic activity. For Keynes, this may occur because entrepreneurs' expectations are not rational (in Muth's sense (1961)) and reflect "animal spirits" (Muth 1974; Tisdell 1971, 1974). Muth's notion means that entrepreneurs often act through mimetism, i.e. there is no diversity in their expectations.

Clearly, Keynes provided a theory of economic fluctuations (including unemployment). These fluctuations, or this economic instability, directly come from a lack of diversity in expectations.

### 3. DIVERSITY OF BEHAVIOURS AND MARKET INSTABILITY

It seems highly probable that economic globalisation or extension of the market system will change the distribution of behaviours and motivation of business firms. For instance, one may begin from a situation where satisficing behaviour is common on a global scale to one in which profit-maximising behaviour is the norm because of increased market competition. In a number of circumstances, this increases the sensitivity of markets and their instability.

We consider the simple cobweb case. We assume for simplicity that all firms face identical economic conditions. In this section, the main assumption is about diversity of behaviours. Even if we consider a unique supply curve at the market level, this curve is built by aggregating firms' supply curves when each firm behaves differently from another one. As noted earlier, there may exist for instance two typical behaviours (e.g. for firms, satisficing or profit maximising). Then, we explain that the proportion of firms which adopt a typical behaviour varies over time as a result of changes in the degree of globalisation. Therefore our purpose is here to show that when diversity decreases it involves changes in the shape of the aggregate supply curve and can lead to market instability.

#### 3.1 *The cobweb dynamics under unconstrained supply curve*

In this sub-section, we assume that firms adopt the same behaviour (they are all profit-maximisers). This case may be considered as what

can happen when globalisation is intense, i.e. when diversity is extremely reduced.

In the simple cobweb model, the demand is strictly decreasing and it depends on the current price:  $Q_t^D = a - b p_t$ , with  $a > 0$  and  $b > 0$ .

The producers predict that the current price of their product will be the same as in the previous period, and so the supply curve is defined as:  $Q_t^S = -c + d p_{t-1}$ , with  $c > 0$  and  $d > 0$ .

The market depends on four parameters  $(a, b, c, d)$ . We assume that  $d > b$ , i.e. the slope of the supply curve is less than the downward slope of the demand curve in absolute value. The supply is therefore more responsive to price variations than the demand (see Figure 1).

FIGURE 1

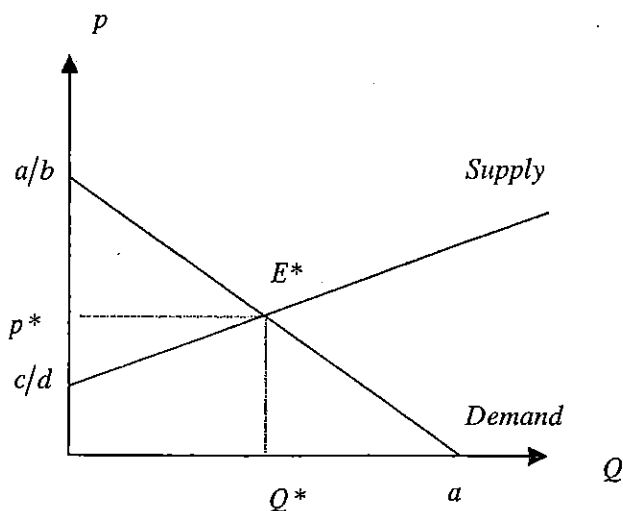

Note that  $c/d$  is positive and may be seen as the minimum of the average cost. The assumption  $d > b$  has important implications, it mainly implies that the equilibrium  $E^*$ , associated to a price  $p^* = (a + c)/(b + d)$  and to a quantity  $q^* = (ad - bc)/(b + d)$ , is not stable. Indeed the supply and the demand curves, put together, lead to a one-dimension dynamics  $p_t = f(p_{t-1})$  with  $f(p) = (a + c)/b - (d/b)p$ .

This dynamics in prices possesses a unique stationary equilibrium  $p^*$ . This equilibrium is unstable if  $|f'(p^*)| > 1$ . Since  $d > b$ , this condition is equivalent to  $f'(p^*) < -1$ . Therefore when  $d > b$ ,  $p^*$  is unstable and the price dynamics is not monotonic (see Figure 2).

FIGURE 2

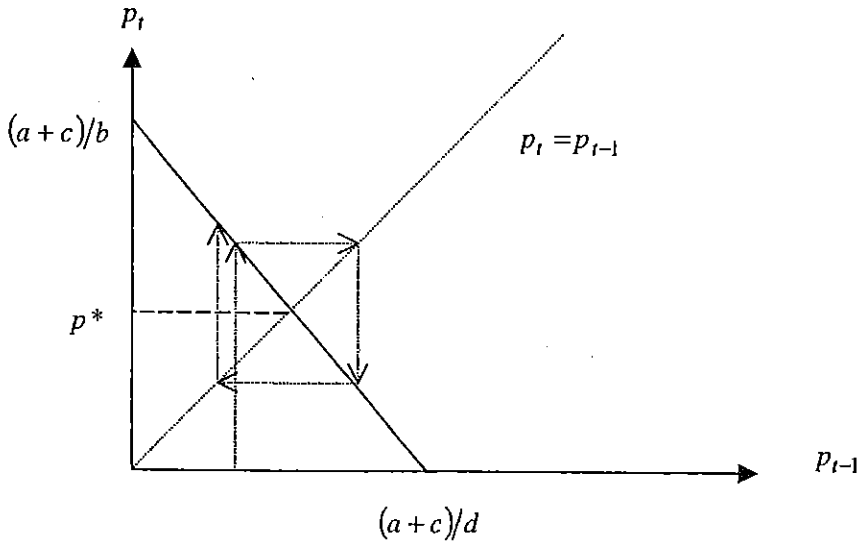

### 3.2 The cobweb dynamics under a constrained supply curve

#### i - Constrained supply curve

We keep the same supply curve of the cobweb model. However, we assume that for any price larger than a given price denoted  $\bar{p}$ , the supply curve remains constant at the level  $\bar{Q}$  associated with  $\bar{p}$ . In other words, the supply curve is now defined as:  $Q_t^S = -c + d p_{t-1}$  if  $p \leq \bar{p}$  and  $Q_t^S = \bar{Q}$  if  $p \geq \bar{p}$ . We then have a "kinked supply curve", i.e. the supply curve is first increasing and then it is upward bounded at an output level equal to  $\bar{Q}$ . When  $\bar{Q}$  goes from zero to infinity, firms shift from considerable diversity towards more responsive uniformity of behaviours.

Let us at least mention three reasons which can explain such a shape.

Firstly, some firms may be engaged in satisficing behaviour and aspire to the same level of economic surplus. Once firms reach the economic surplus to which they aspire, their supply is perfectly elastic. Of course when  $\bar{Q}$  tends to infinity, a larger proportion of firms is becoming profit-maximiser. On the contrary, when  $\bar{Q}$  tends to zero, more firms are engaged in strong satisficing. In this case, the supply curve is upward constrained.

Secondly, in a given market, some firms may have market power and may be gathered in a cartel. Therefore,  $\bar{Q}$  may be seen as the

largest output that the cartel has decided to produce<sup>1</sup>. Of course, voluntary constrained output is motivated here by the seek of larger profits.

Thirdly, the production may require a specific input (e.g. capital) not available in large quantities. Then the total output is constrained by external elements to firm's behaviour or goals (in fact by the technical process).

#### ii - The dynamics

We keep the same cobweb model and also the same assumption  $d > b$ . This assumption implies that, when the stationary equilibrium does not belong to the vertical part of the supply curve, the equilibrium remains the same (i.e.  $E^*$  as depicted in Figure 1) and is unstable.

In fact two cases can appear depending on whether  $\bar{Q}$  is below or above the initial equilibrium market output denoted by  $Q^*$  (see Figure 3).

FIGURE 3

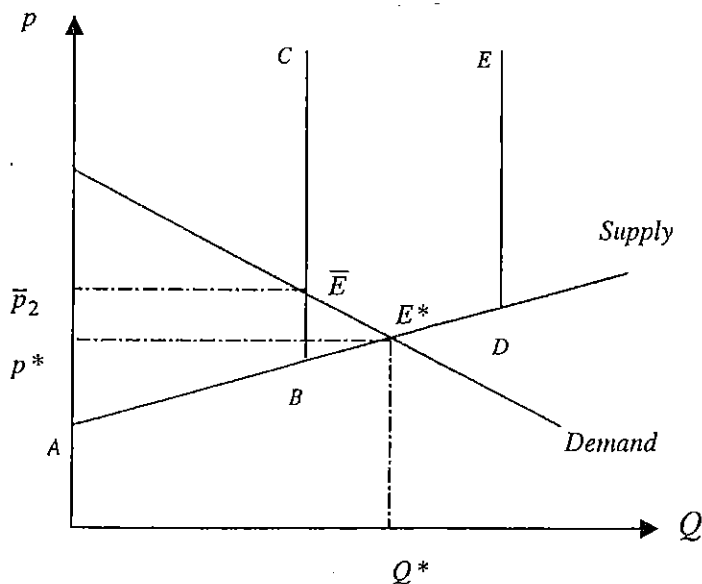

<sup>1</sup> For simplicity we assume that the output of the remaining firms (firms out of the cartel) is negligible.



When  $\bar{Q}$  is below  $Q^*$  the supply curve is  $(A, B, C)$ . Note that the equilibrium is now  $\bar{E}$ .

When  $\bar{Q}$  is above  $Q^*$ , the supply curve is  $(A, D, E)$  and the equilibrium remains  $E^*$ .

The dynamics is divided into two parts (as for the tent function), it is defined as  $p_t = f(p_{t-1})$  with  $f(p) = (a+c)/b - (d/b)p$  if  $p \leq \bar{p}_i$  and  $f(p) = \bar{p}_i$  if  $p \geq \bar{p}_i$  with  $i=1$  or  $2$ .

Of course the dynamical system clearly depends on the value of  $\bar{p}_i$ . As shown on Figure 4, two cases are possible.

FIGURE 4

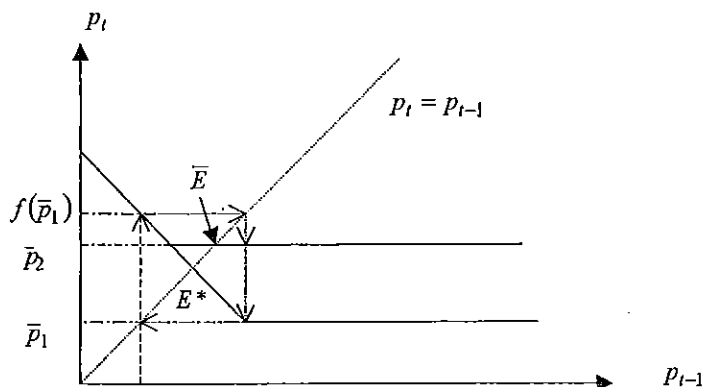

Let us first deal with the case where  $\bar{Q} > Q^*$ . There is still a unique stationary equilibrium,  $E^*$ , associated to a price  $p^*$ , which is unstable. However, a two-cycle appears in its neighbourhood. This cycle is a 2-period cycle and therefore the price path is  $\{\dots, \bar{p}_1, f(\bar{p}_1), \bar{p}_1, f(\bar{p}_1), \dots\}$ . Since  $E^*$  is unstable, the 2-period cycle is stable.

When  $\bar{Q} < Q^*$ , there is a unique stationary equilibrium  $\bar{E}$ , associated to a price  $\bar{p}_2$ . This equilibrium is stable.

### 3.3 Diversity of behaviours and globalisation

It clearly appears from sub-sections 3.1 and 3.2 that any departure from an unconstrained supply curve increases market stability. Indeed

let us recall that when the supply curve is unconstrained there is a unique equilibrium which is unstable. When the supply curve is constrained, the market is stabilised. This may take the form of a stable 2-period cycle or of a new equilibrium which is stable.

A question arises: how could we explain the changes of the shape of the supply curve? The answer lies in globalisation. For that purpose we go back to the three reasons mentioned earlier. Let us start from a situation where globalisation is not intense.

Firstly, without large globalisation there is low competition, i.e. firms are sheltered from international competition and therefore they may adopt behaviour based on satisficing rather than on profit maximising. The level of satisficing is equal to  $\bar{Q}$ . When globalisation increases, firms are not able to keep the same level of satisficing. They must be more "profit maximisers" and  $\bar{Q}$  increases. If we consider the bifurcation diagram (see Figure 5), we could see that market instability is growing up as soon as globalisation increases.

FIGURE 5

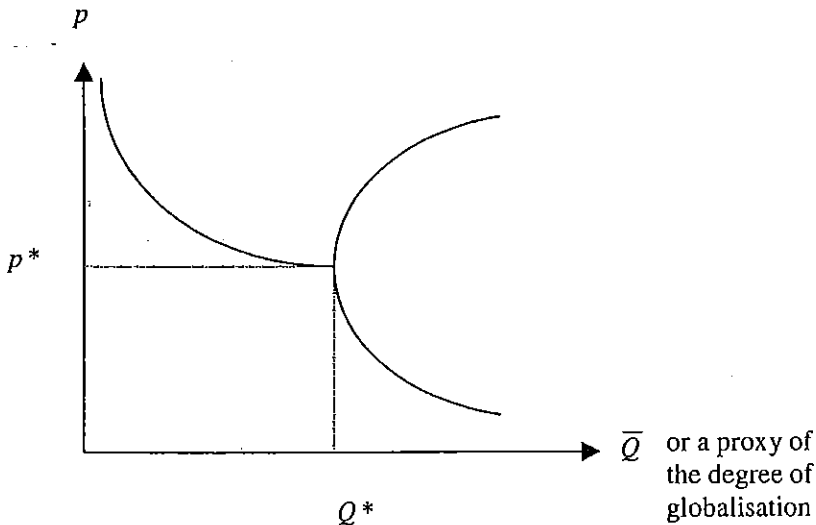

Indeed on Figure 5 we start from a stable equilibrium; when globalisation increases, firstly the equilibrium price decreases<sup>2</sup>, and

<sup>2</sup> The total output increases in this first part. So, we may say that globalisation has positive effects when it is not too intense.

after  $Q^*$  the equilibrium is unstable and a 2-period cycle appears. However, even if the cycle is stable, its magnitude increases with the degree of globalisation<sup>3</sup>. Clearly, a switch from satisficing to maximising behaviour destabilises the market.

Such a switch may be explained as follows. Let us consider two geographically separated markets with the same characteristics. In each market the same good is produced but the markets are separated because of high trade barriers. Each market involves a high proportion of satisficers to keep them stable, but there are some profit-maximisers firms. Because of globalisation, both markets stop being separated and merge. Satisficers of each market have then new competitors: the satisficers and the profit-maximisers of the other market. Their behaviours may change in two ways, depending on the fear of their opponents. If all satisficers cooperate with each other, then the world economy remains stable. If some satisficers are afraid of their new competitors and adopt a profit-maximiser behaviour, the world economy is more than likely to become unstable. However the latter case is more willing to happen. Indeed, when globalisation increases, competitive pressure is enhanced and then firms give up cooperative strategies. Instability may thus be associated to a non cooperative equilibrium and thus to an inefficient outcome.

Streeten (1998) brings attention to a view expressed by Myrdal (1951) which is indirectly relevant to this example. Streeten (1998: 546) says "In this important though neglected article Myrdal argued that free markets worked best when people acted not like economic men, but were bound by conventions and taboos". If we consider that economic men are profit-maximisers and that satisficers act via conventions and taboos, then Myrdal approach and ours are very close: when people act more like economic men, many markets are liable to become unstable.

Secondly, when globalisation increases, the market power of any cartel decreases (because other firms or substitutes are entering into the market). Then the cartel is not able to maintain a low level of total output, otherwise some other firms will capture its customers. Therefore,  $\bar{Q}$  increases via larger globalisation and instability is enhanced.

Thirdly, globalisation is the term that has emerged to capture the rapid increase in international trade and capital flows. Without large

---

<sup>3</sup> The emergence of larger and larger fluctuations may be considered as some of the negative effects associated with intense globalisation.

capital flows, the supply of commodities may be bounded in several countries. With globalisation, the supply is not constrained and here again this has led to more market instability.

#### 4. CHANGED GOALS AND MARKET INSTABILITY

We still consider the previous cobweb model and we first assume that the equilibrium remains unstable and that now the supply curve is not upward bounded.

In this section, our purpose is to show that globalisation implies changes in the slope of the supply curve and that it leads to the destabilisation of the market. Of course when goals are changing, our assumption about  $d > b$  must be relaxed. Three cases are subsequently studied: the variations in X-efficiency, the variations in market transactions costs, and the changes in the distribution of motivation.

##### 4.1 *Variations in X-efficiency*

In the above discussion, it is assumed that no X-efficiency is present. However, it is more likely to be present when market competition is not strong. If the presence of economic inefficiency in production tends to make the actual market supply curve steeper than it otherwise would be, it is a force making for market stability in the simple cobweb case. The removal or reduction in such inefficiency as a result of greater competition due to globalisation will, in such a case, tend to increase market instability.

##### 4.2 *Variations in market transactions costs*

An additional influence can be reductions in market transaction costs accompanying market expansion. If total market transaction costs rise with the volume of transactions but at a declining rate, the supply curve taking account of market transaction costs has its slope reduced. This makes supply more responsive to market price than when total transaction costs either increase at a constant or an increasing rate. Consequently, the likelihood of the market becoming unstable in the simple cobweb case increases, assuming that profit maximisation is the rule.

Note that as suggested by Tisdell (2000) it is not the absolute level of market transaction costs which are important for market stability in this case, but the rate of change such costs. To the extent

that globalisation is associated with economies of scale in market transaction costs, it could be a destabilizing market force.

#### 4.3 Changes in distribution of motivation

In this case, firms satisfy and so the supply curve of any firms is constrained. However all suppliers are assumed not to have the same motivations or goals. If all satisfy but their aspiration levels form a continuously distributed frequency distribution, the effect is to make the actual supply curve for an industry steeper than it otherwise would be for profit-maximising behaviour. This lower supply response, in the simple cobweb case, exerts a stabilising influence on the market. Similarly if the proportion of profit-maximising suppliers rises, the actual supply curve for the market becomes more responsive to market price and the chances that the market will become unstable rise. This is the most likely consequence of extension of markets as a result of globalisation. We illustrate this case in Figure 6.

FIGURE 6A

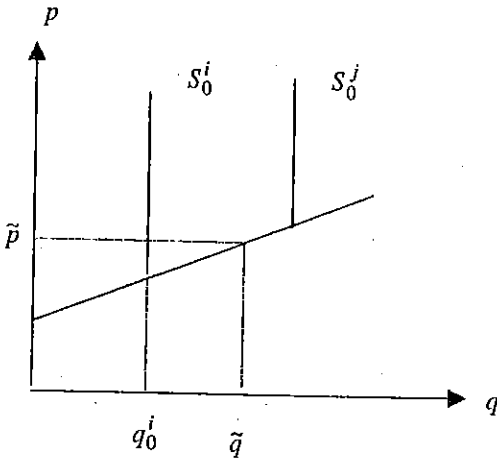
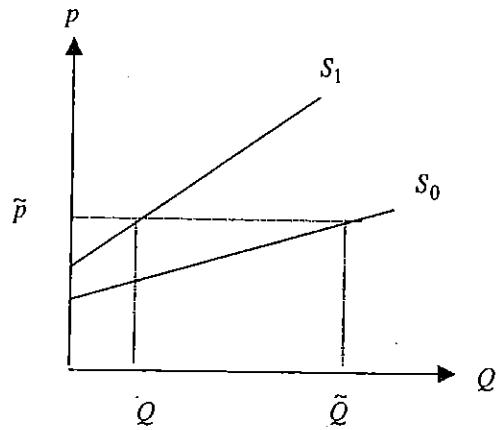

FIGURE 6B



For any  $\tilde{p}$  the supply of firm  $i$  is  $q_0^i$  and the supply of firm  $j$  is  $\tilde{q}$  (see Figure 6.a). If there are only two firms on the market (firms  $i$  and  $j$ ), then the total output is  $Q = q_0^i + \tilde{q}$  which is different from  $\tilde{Q} = \tilde{q} + \tilde{q}$ . Since  $q_0^i < \tilde{q}$  then  $Q < \tilde{Q}$ . In other words, the supply curve is steeper (see Figure 6.b).

## 5. CONCLUDING COMMENTS

The previous analysis suggests that globalisation should be, at any level, managed. Our approach is then similar to Tobin's approach regarding international capital flows and the famous "Tobin's tax". We do not consider that globalisation is harmful *per se* but, since it tends to increase market instability through the reductive diversity of behaviours, we consider that a "minimum level" of diversity must be maintained if a reasonable degree of market stability is to be preserved.

LAURENCE LASSELLE

*University of St. Andrews, Department of Economics, St. Andrews, Fife, U.K.*

SERGE SVIZZERO

*CERESUR, Université de La Réunion, Faculté de Droit et des Sciences Economiques, Ile de La Réunion, France*

CLEM TISDELL

*The University of Queensland, Department of Economics, Brisbane, Qld, Australia*

## REFERENCES

- AOKI, M. (1998), «New Economics of Diversity: comparative institutional analysis», *Journal of Japanese Trade and Industry*, Nov-Dec.
- GRANDMONT, J.M. (1993), «Behavioural Heterogeneity and Cournot Oligopoly Equilibrium», *Discussion Paper No A402*, Universität Bonn.
- HICKS, J.R. (1946), «Value and Capital», 2<sup>nd</sup> Edition. Oxford: Oxford University Press.
- HILDENBRAND, W. (1983), «On the "Law of Demand"», *Econometrica* 51(4): 997-1019.
- KEYNES, J.M. (1936), *The General Theory of Employment, Interest and Money*, Harcourt Brace.
- MUTH, J. (1961), «Rational Expectations and the Theory of Price Movements», *Econometrica* 29: 314-335.
- MUTH, J. (1974), «A Note on Economic Policy, Forecasting and Flexibility», *Weltwirtschaftliches Archiv*. 110(1): 173-75.
- MYRDAL, G. (1951), «The Trend Towards Economic Planning», *Manchester School Papers*, 19 (1): 1-42.
- PARETO, V. (1896), *Cours d'Economie Politique*, Lausanne, Rouge, 1896-1897.

- SAMUELSON, P.A. (1947), *Foundations of Economic Analysis*, Cambridge, Mass.: Harvard University Press, 1947.
- SCITOVSKY, T. (1976), *The Joyless Economy*, Oxford University Press, New York.
- STREETEN, P. (1998), «The Cheerful Pessimist: Gunnar Myrdal the Dissenter (1898-1987)», *World Development*, 26(3), 539-50.
- TISDELL, C.A. (1968), *The Theory of Price Uncertainty, Production and Profit*, Princeton University Press, Princeton.
- TISDELL, C.A. (1971), «Economics Policy, Forecasting and Flexibility», *Weltwirtschaftliches Archiv* 196(1): 34-54.
- TISDELL, C.A. (1974), «Comments on Muth's Note on Economic Policy Forecasting and Planning», *Weltwirtschaftliches Archiv* 110(1): 176-77.
- TISDELL, C.A. (1986), *Bounded Rationality and Economic Evolution*, Edward Elgar, Cheltenham, UK.
- TISDELL, C.A. (1999), «Diversity and Economic Evolution: Failures of Competitive Economic Systems», *Contemporary Economic Policy* 17(2): 156-65.
- TISDELL, C.A. (2000), «Transaction Cost and Bounded Rationality Theory: Flawed and So Ignored in Public Policy?», *Department of Economics Discussion Papers* No. 273. The University of Queensland, Brisbane.
- WALRAS, L. (1874), *Éléments d'Economie Politique Pure*, Lausanne, Corbaz, 1874-1877, translated as *Elements of Pure Economics*, Homewood, Ill., Irvin, 1954.

## ABSTRACT

Globalisation has become extremely intense since the earlier seventies. Given that the world economy is getting close to a single market, a more efficient outcome via globalisation can be expected. However, globalisation may also have negative effects. We illustrate our findings through a simple cobweb model where we analyse different shape and slope of the aggregate supply curve. We show that when globalisation is too intensive, it leads to more instability on markets because of a reduction of behavioural diversity.

The economic literature indicates that this diversity can be necessary for market stability as well as for macro-economic stability. We demonstrate that as a result of globalisation, the goals or motivations of economic agents may become more uniform (more profit-oriented) and generate market instability.

Keywords: Diversity, Globalisation, Heterogeneity of Behaviour, Instability

JEL Classification: D21, D4

## RIASSUNTO

*Diversità, globalizzazione e stabilità dei mercati*

La globalizzazione è diventata estremamente intensa dall'inizio degli anni '70. Poiché l'economia mondiale si sta avvicinando ad un mercato unico, è prevedibile una crescita dell'efficienza complessiva. Tuttavia la globalizzazione può anche comportare effetti negativi. I risultati di questo lavoro vengono illustrati utilizzando un semplice modello cobweb in cui si analizzano la diversa forma e pendenza della curva della domanda aggregata. Si dimostra che quando la globalizzazione è troppo intensa si ha una maggiore instabilità nei mercati a causa di una minore diversità nei comportamenti.

La letteratura economica indica che tale diversità può essere necessaria per la stabilità dei mercati e per la stabilità macroeconomica. Nel lavoro si dimostra come, in conseguenza della globalizzazione, gli obiettivi o le motivazioni dei soggetti economici possano diventare più uniformi (più orientati al profitto) e generare instabilità nei mercati.